

SunWize Power & Battery Aluminum Skid Manual

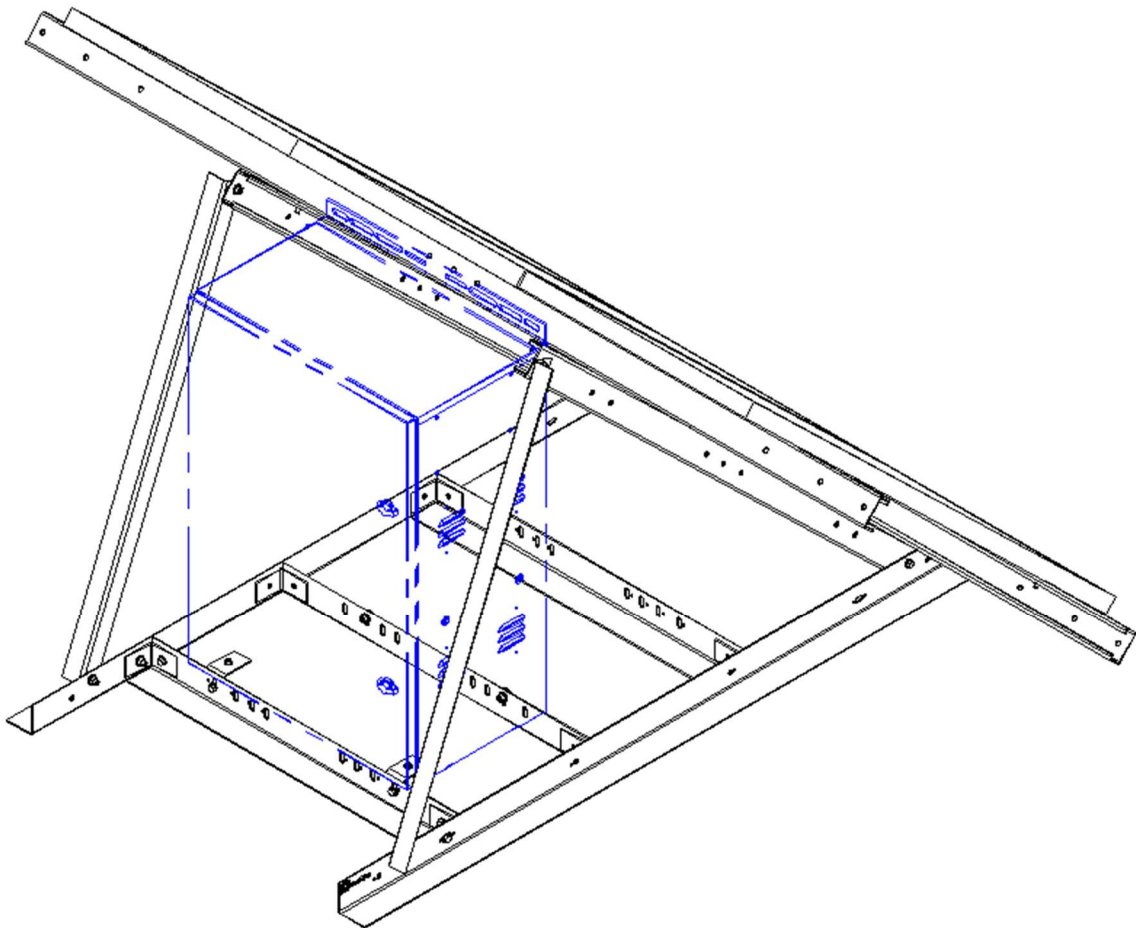

Visit our website:



Included Parts:

A) 2x Base Side Rail

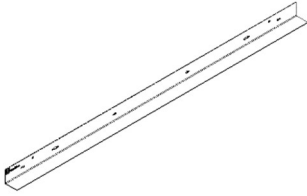

B) 3x Base Cross Rail

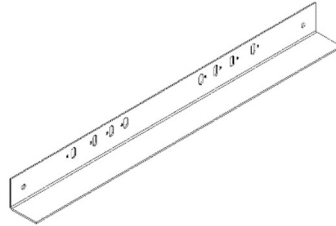

C) 6x Angle Clip

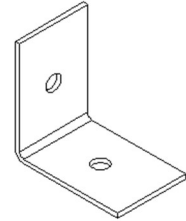

D) 2x Upright

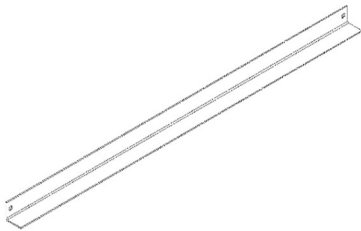

E) 2x Module Cross Rail



F) 2x Module Base Rail



G) 3/8" Flange Nut



H) 1/4" Flange Nut



I) 3/8" Carriage Bolt

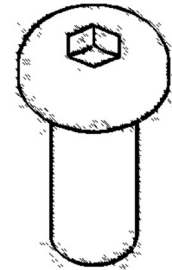

J) 1/4" Flange Bolt

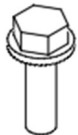

K) 1x Anti-Seize Packet



K) 1x Allan Key



Ballast and Positioning

- The *SunWize Aluminum Skid* should not be easily movable after installation.
- Modules need to face south (Northern Hemisphere) with unobstructed view of the sun.
- The foundation that the *SunWize Aluminum Skid* rest on needs to be flat and solid:
 - Concrete slab
 - Firm soil
 - Even Gravel
- Use cinder blocks or other concrete building material as a ballast. See table below for recommended ballast based on wind load. Weight of batteries and enclosure not included in ballast weight.

Wind Speed vs Required Ballast	
Max Wind Speed (MPH)	Ballast Weight (lb)
30	0
40	50
50	100
60	160
70	240
80	320
90	420

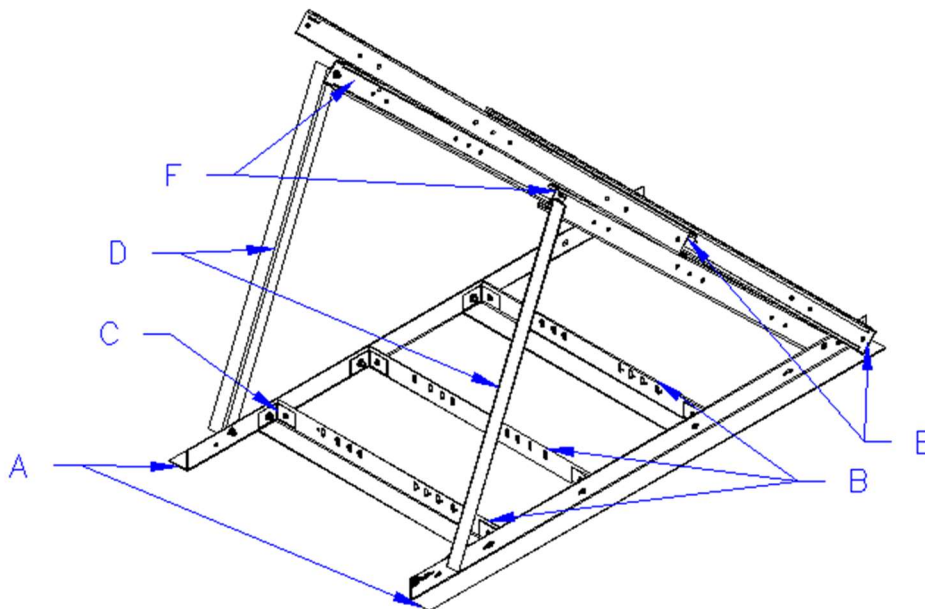
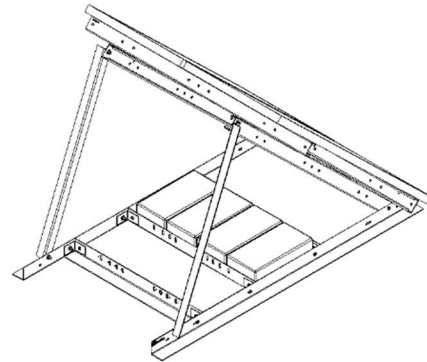

Aluminum Skid Assembly

1. Assemble base as shown below. Bolt the base side rails to the cross bars through the hole marked "D".

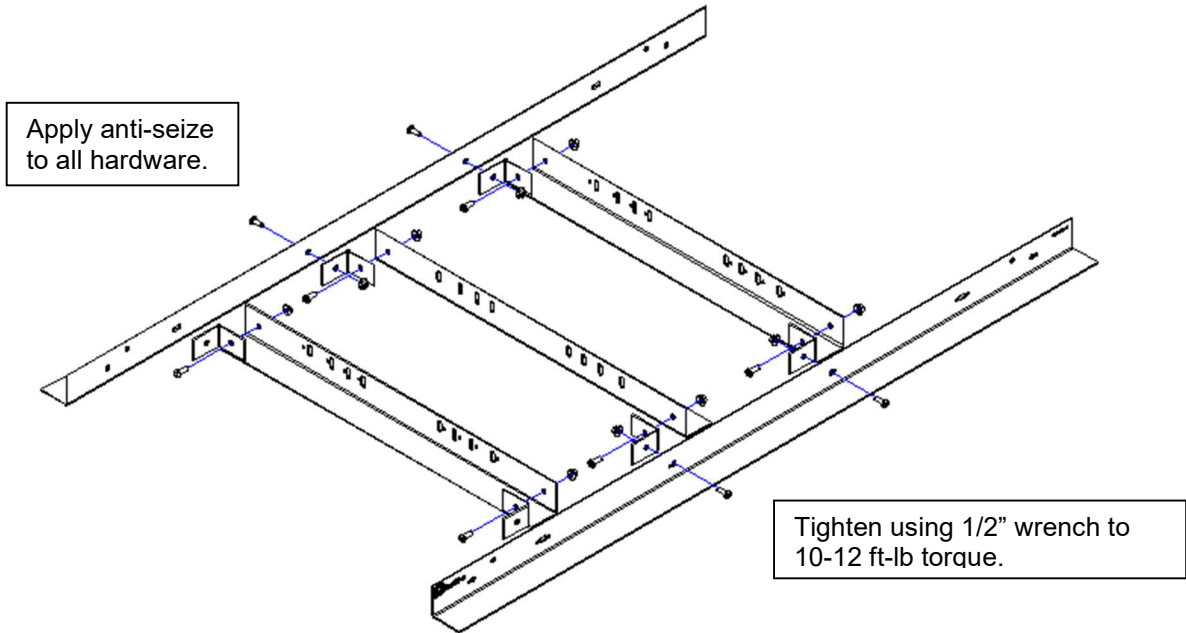

2. If mounting an enclosure, reference the *Sunwize Aluminum Skid Enclosure Manual*. Otherwise, attach the loose cross bar by bolting through the holes marked "A". Enclosure shown in blue.

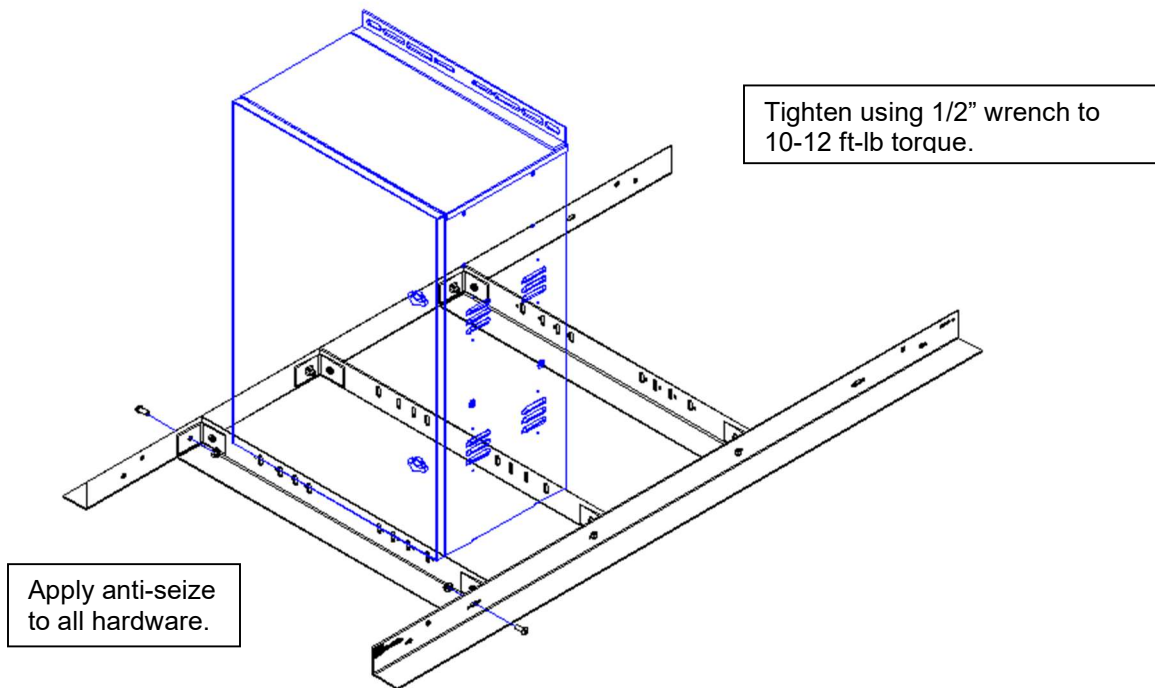

3. Attach module base rails to the skid base.

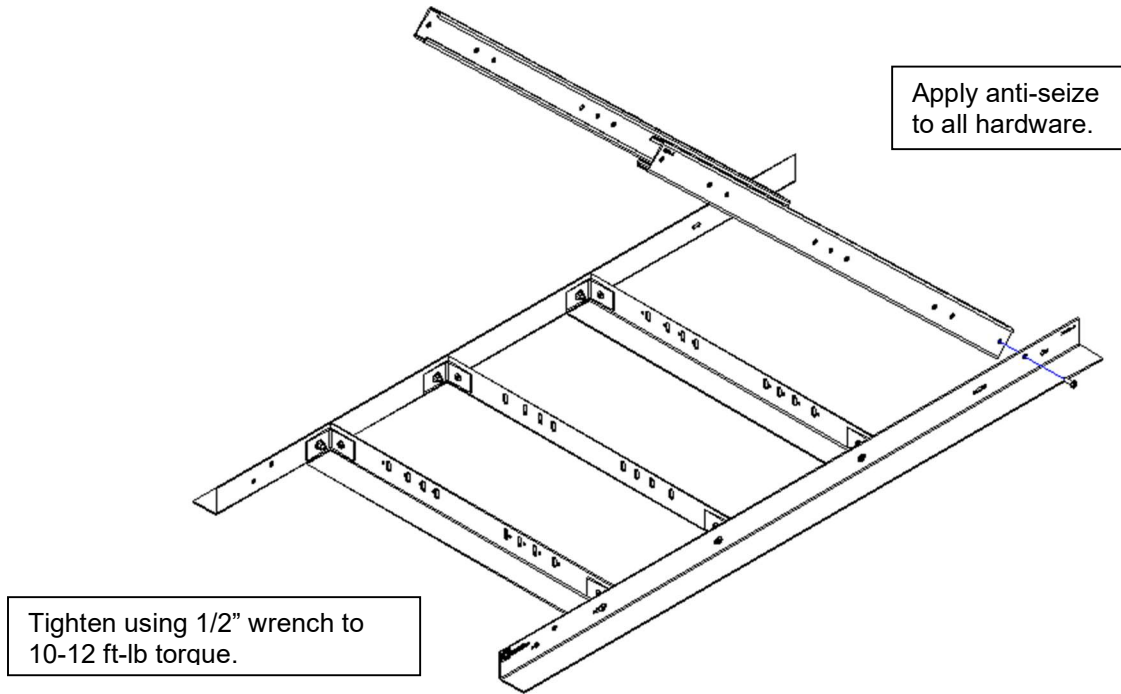

4. Attach uprights to skid base and module base rails.

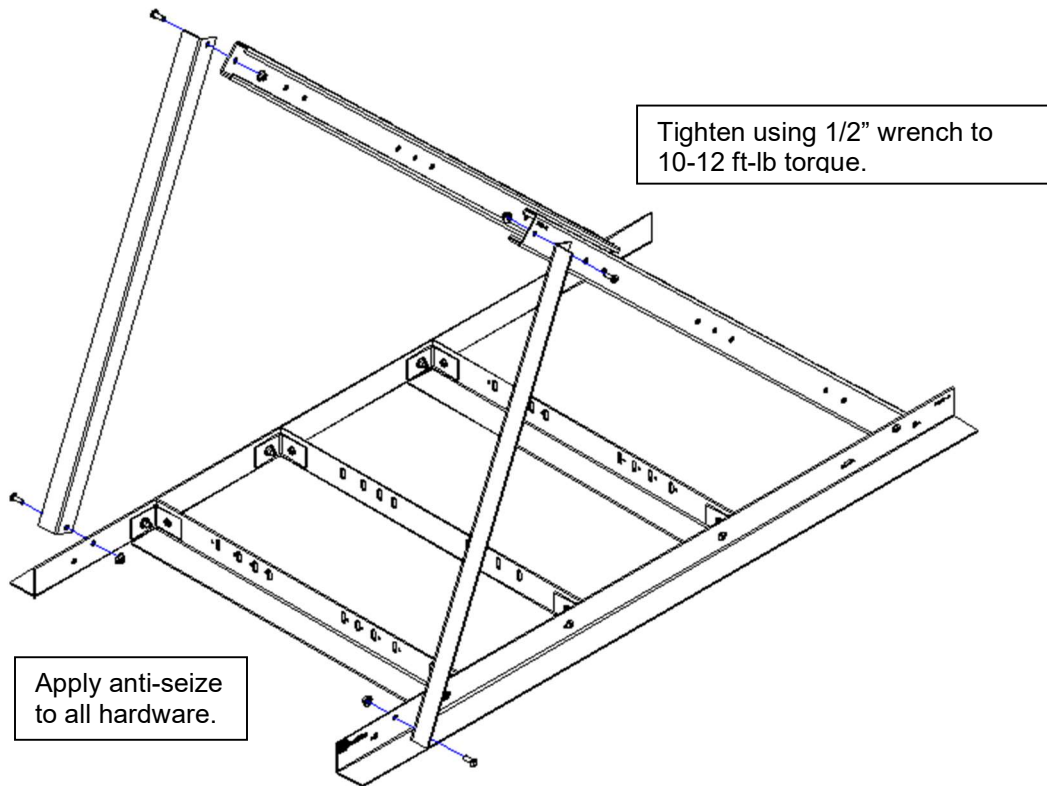

5. Bolt module cross bars to the module base rails.

Apply anti-seize to all hardware.

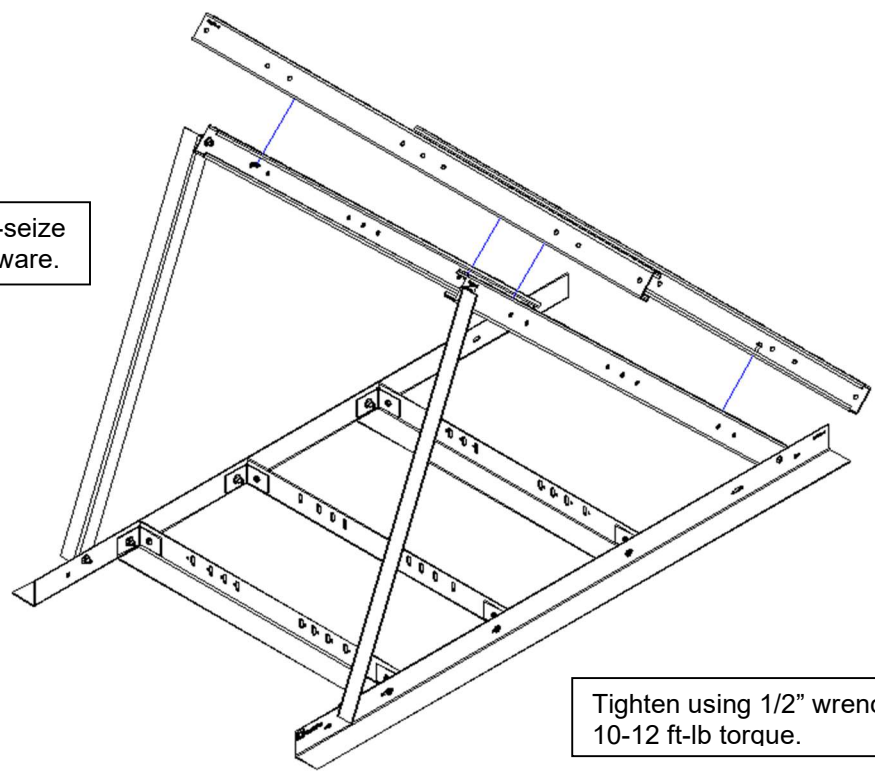

Tighten using 1/2" wrench to 10-12 ft-lb torque.

6. Mount the solar modules to the rails using the 1/4" hardware provided.

Apply anti-seize to all hardware.

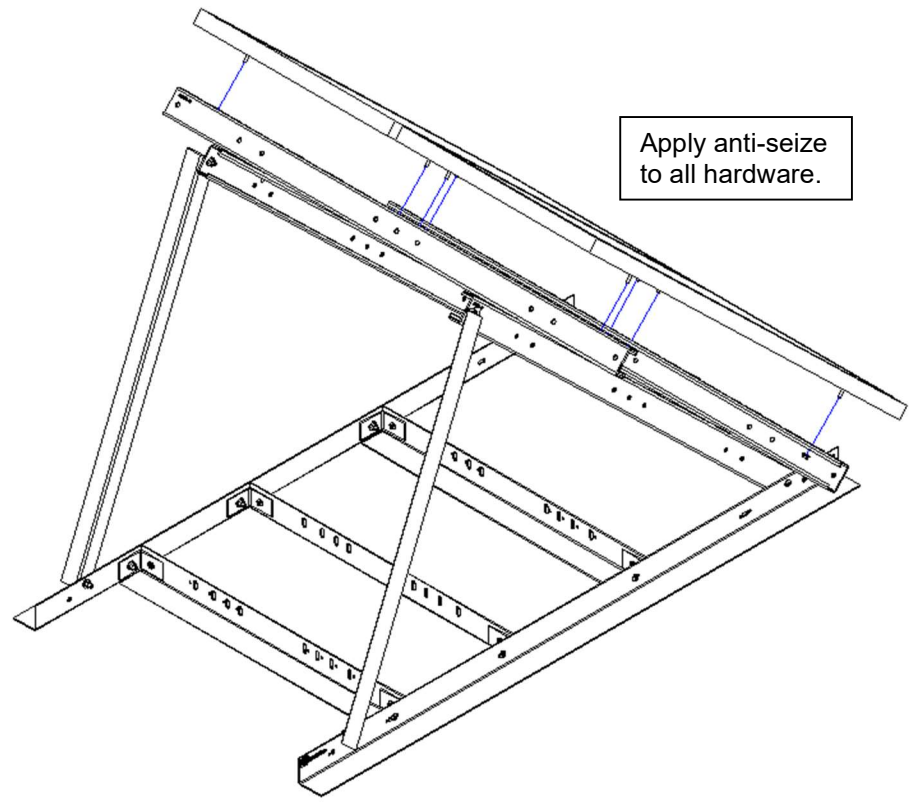

7. Check alignment of all assembled parts and ensure all bolted connections are tight.

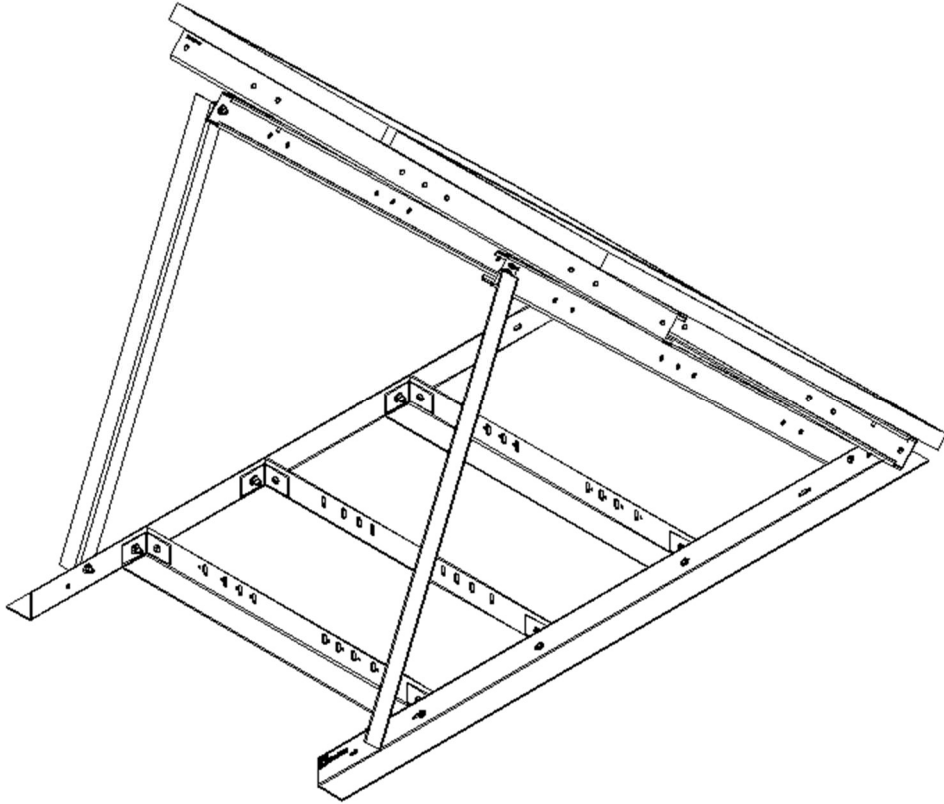

8. Install ballast on skid. Reference page 3.

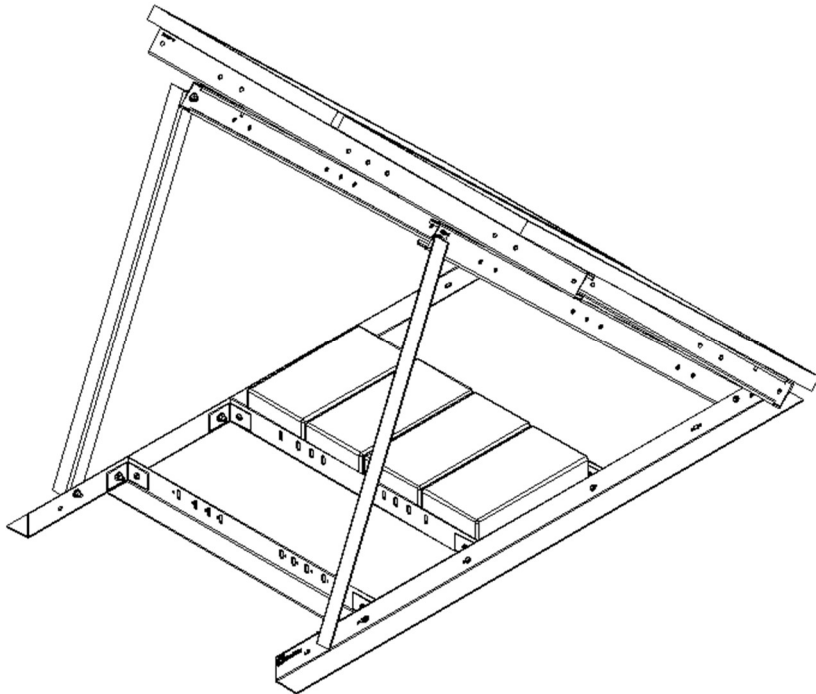

SunWize Power & Battery Aluminum Skid Enclosure Manual

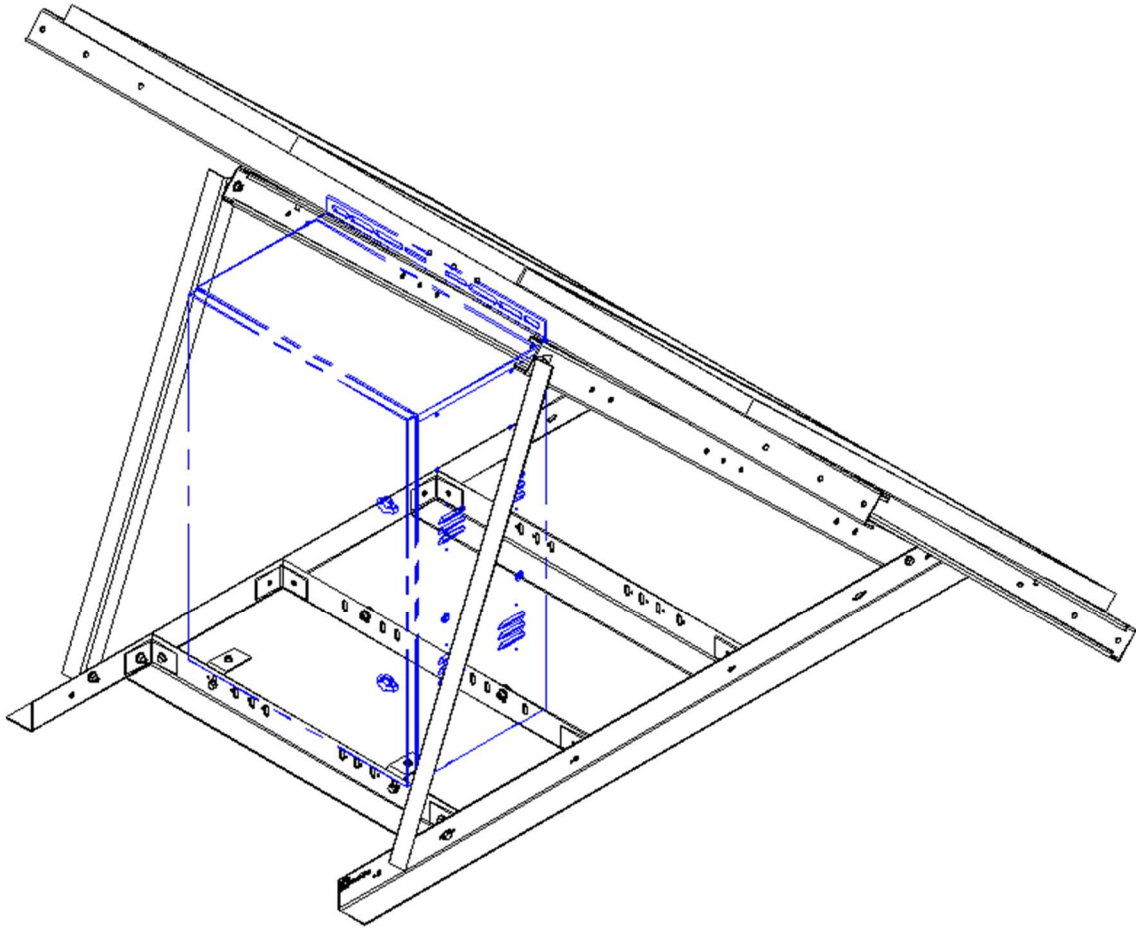

M2-8D Enclosure Mounting

1. Bolt the loose base cross rail through the slot on the side marked "B" using 3/8" hardware.

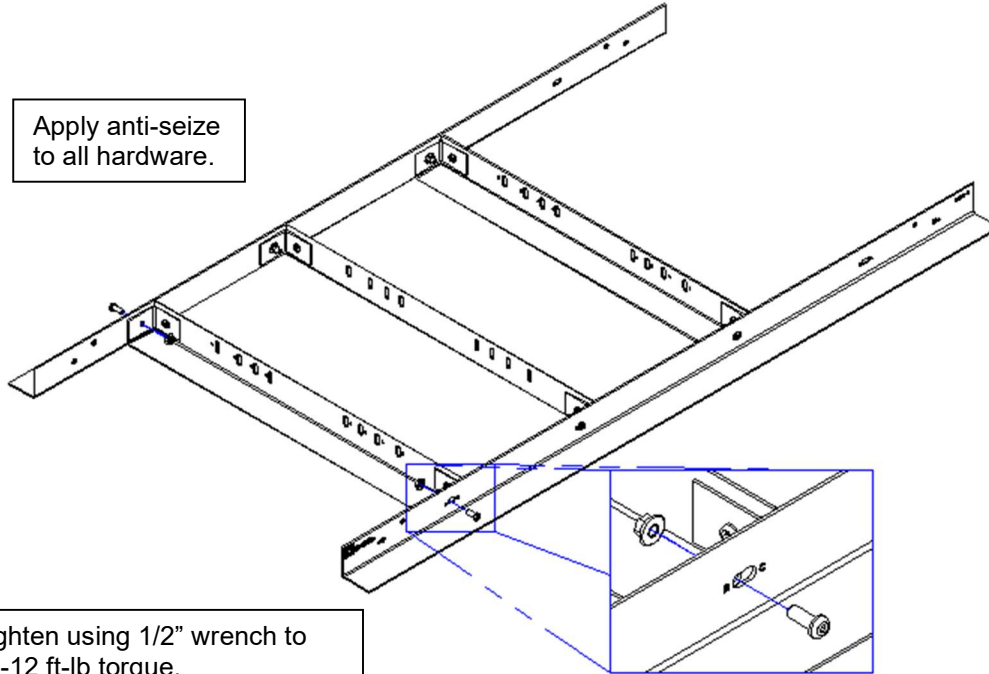

2. Install angle clips, bolting through the hole marked "1" on each side using 3/8" hardware. **Do not fully tighten.**

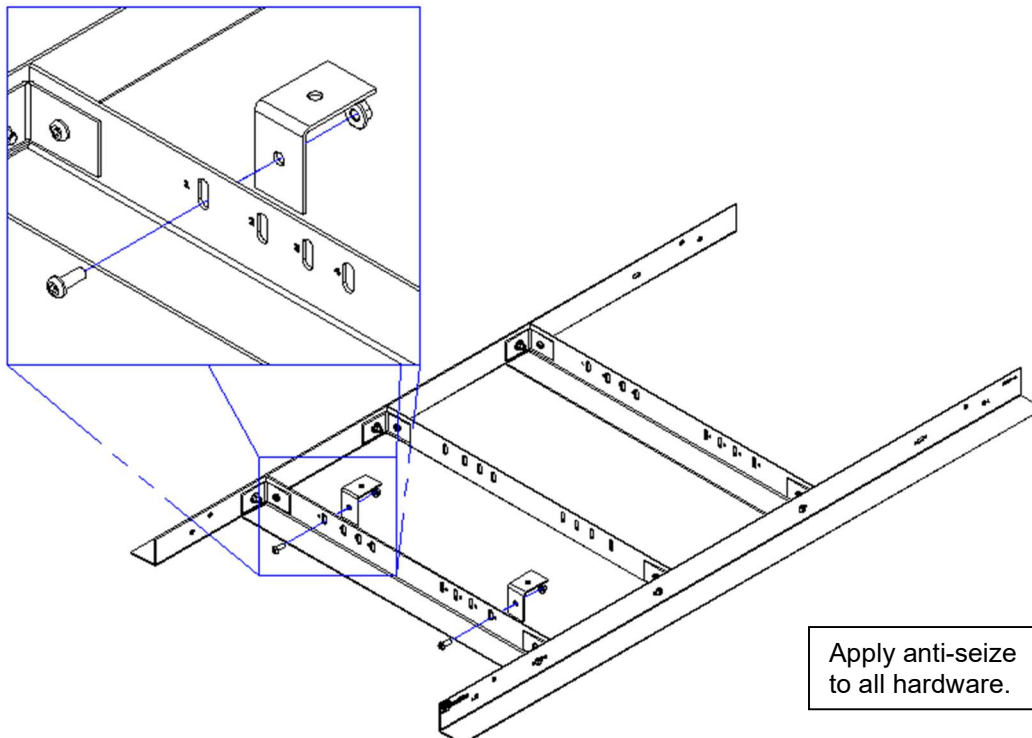

3. Turn enclosure onto its back and drill out the two existing holes in the floor of the enclosure (Shown in red) using a $\frac{1}{2}$ " drill bit.

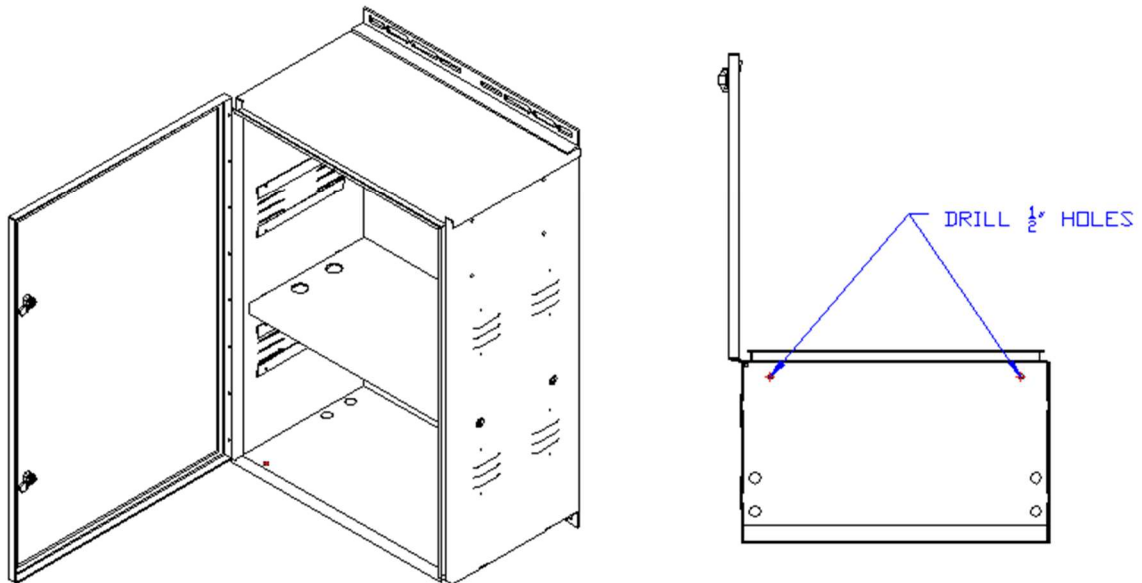

4. Lower enclosure onto angle clips and bolt through holes in the floor of the enclosure using $\frac{3}{8}$ " hardware and carriage bolts. **Do not fully tighten.**

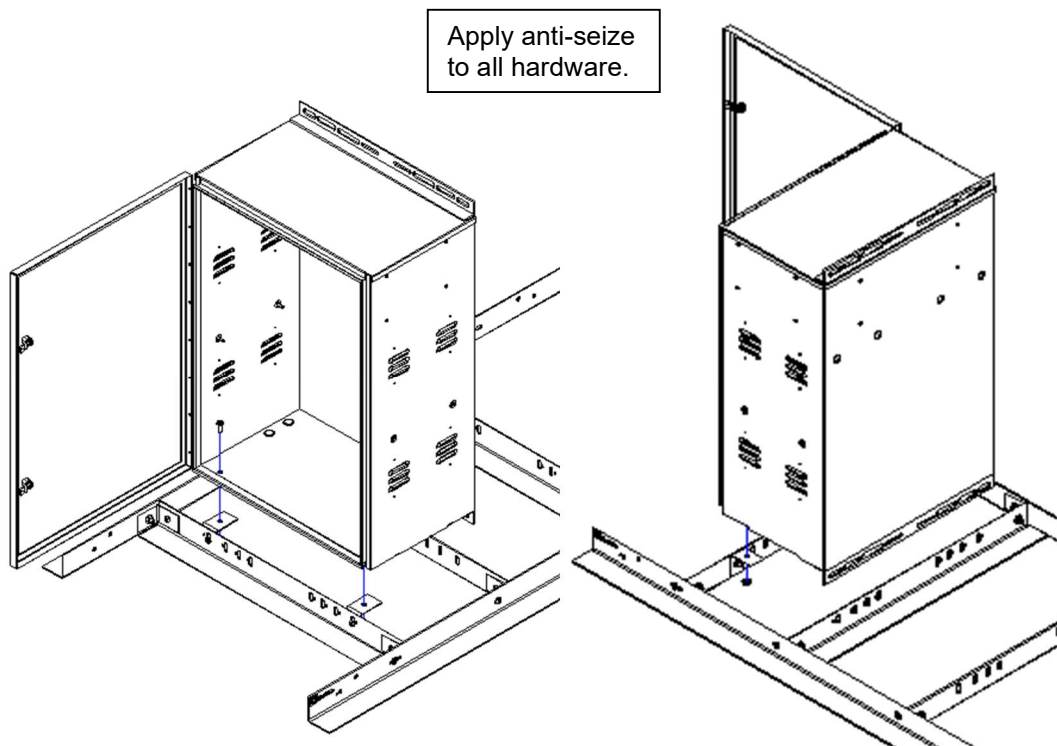

5. Bolt the rear of the enclosure to the skid through the holes marked "2" using 3/8" hardware and carriage bolts. **Do not fully tighten.**

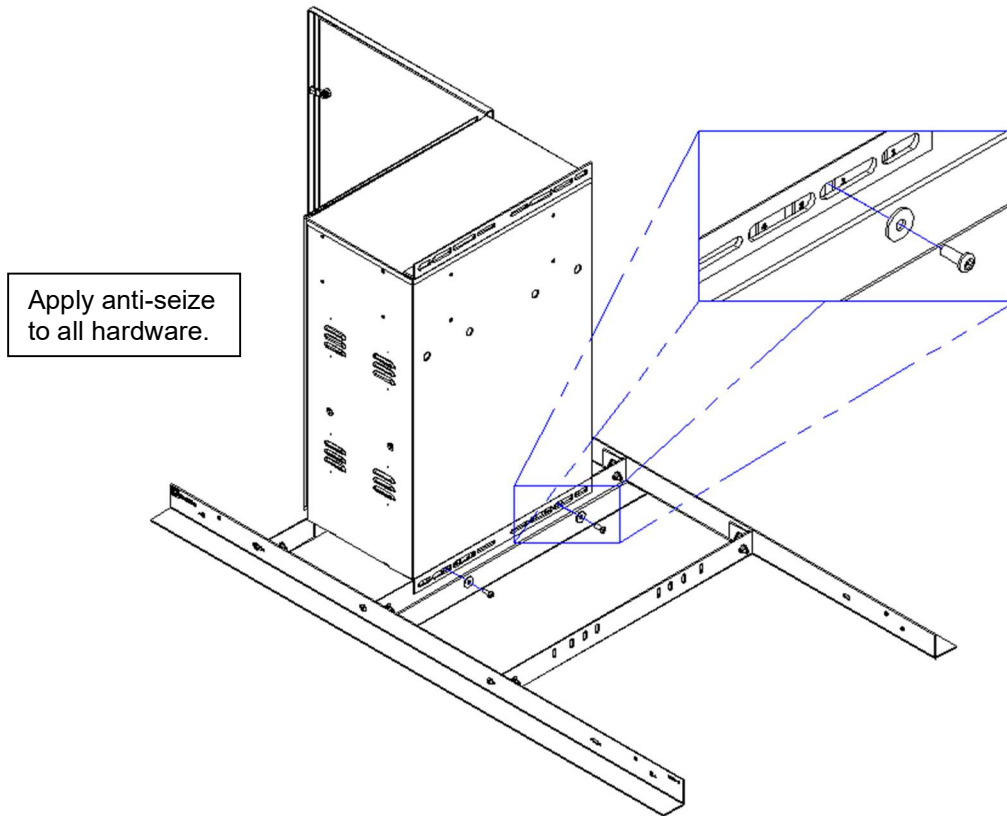

6. Tighten all hardware using 1/2" wrench to 10-12 ft-lb torque.
7. Check the enclosure is fully secured to the base and aligned correctly.

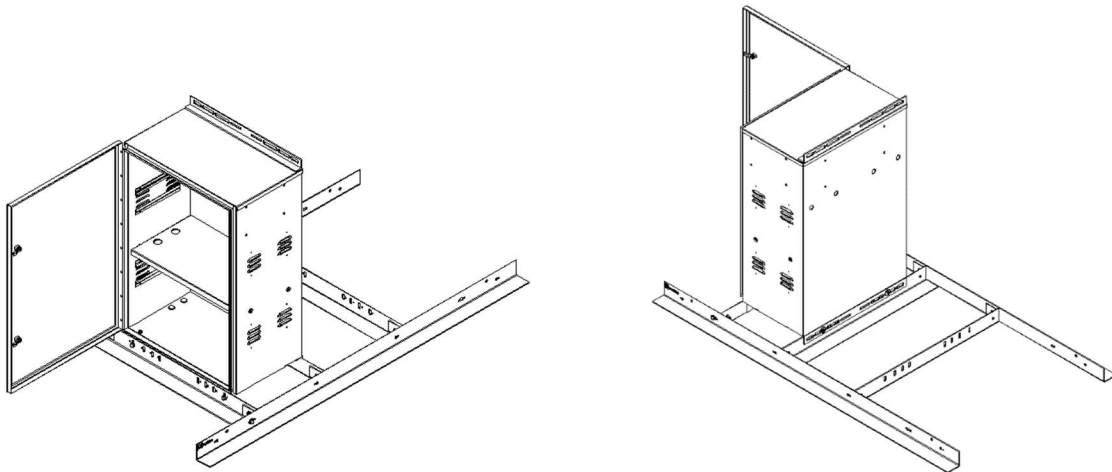

M1-8D Enclosure Mounting

1. Bolt the loose base cross rail through the slot on the side marked "C" using 3/8" hardware.

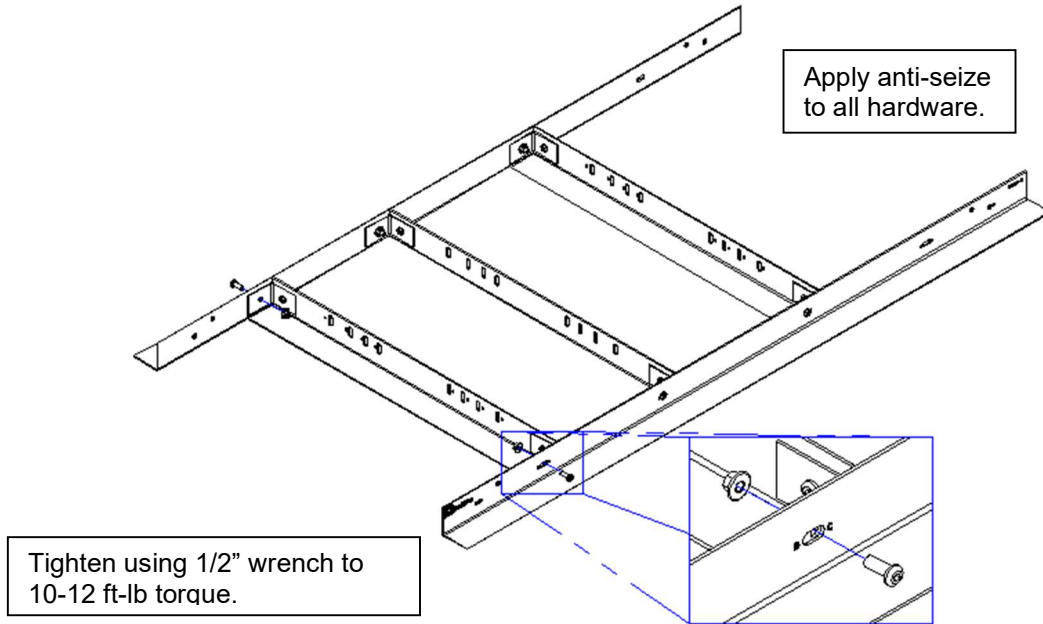

2. Install angle clips, bolting through the hole marked "1" on each side using 3/8" hardware. **Do not fully tighten.**

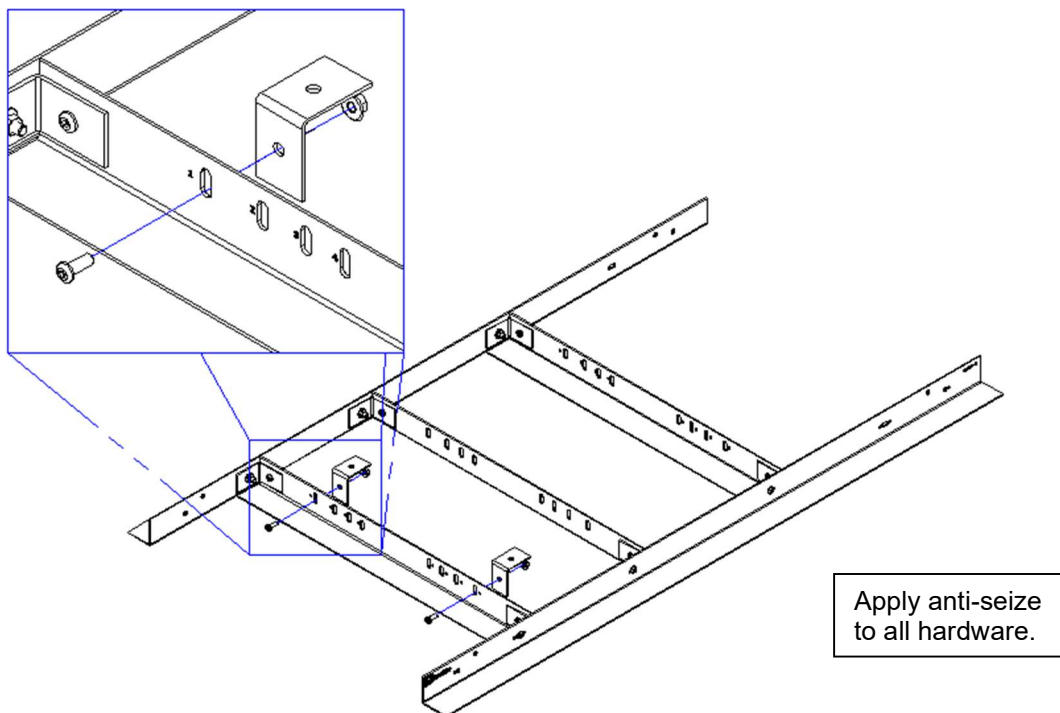

3. Turn enclosure onto its back and drill out the two existing holes in the floor of the enclosure (Shown in red) using a $\frac{1}{2}$ " drill bit.

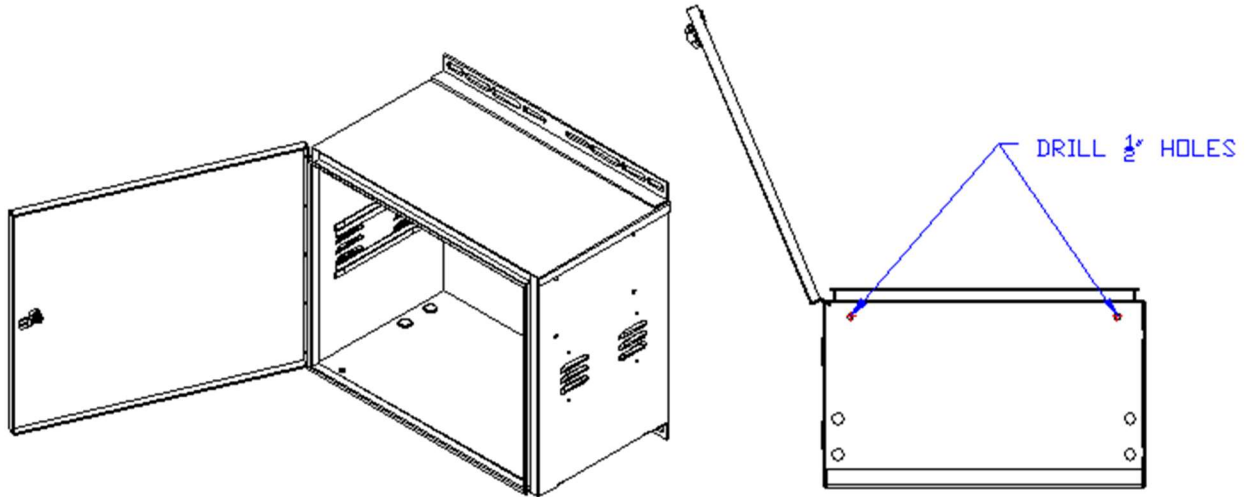

4. Lower enclosure onto angle clips and bolt through holes in the floor of the enclosure using $\frac{3}{8}$ " hardware and carriage bolts. **Do not fully tighten.**

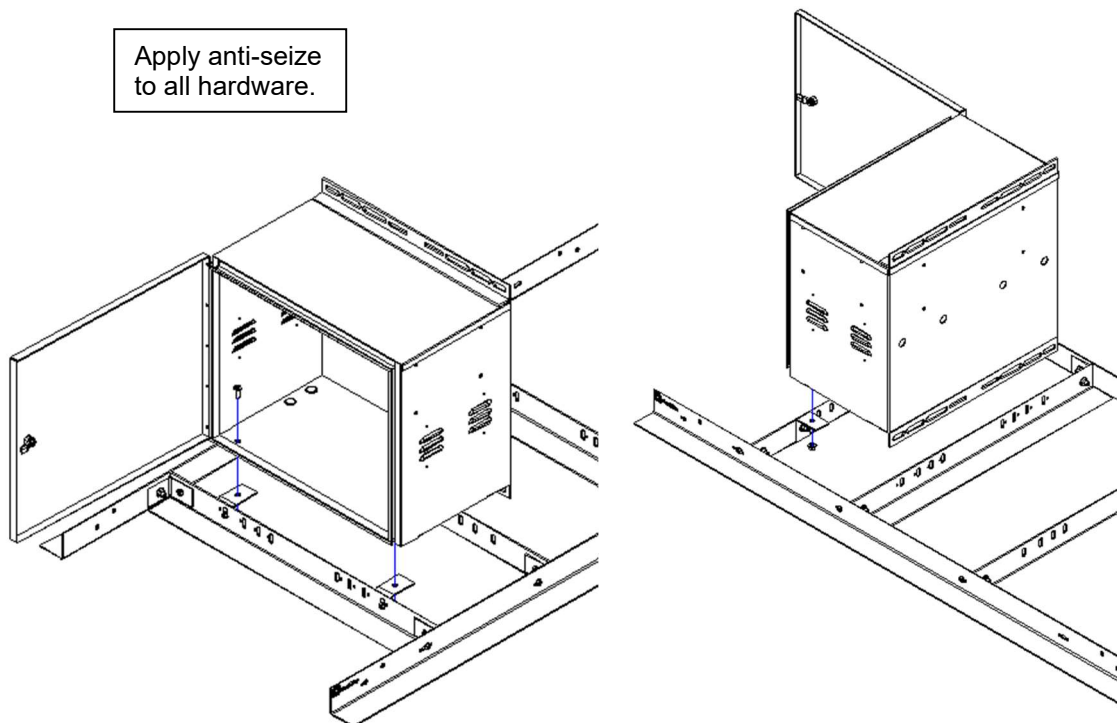

5. Bolt the rear of the enclosure to the skid through the holes marked "2" using $\frac{3}{8}$ " hardware and carriage bolts. **Do not fully tighten.**

Apply anti-seize to all hardware.

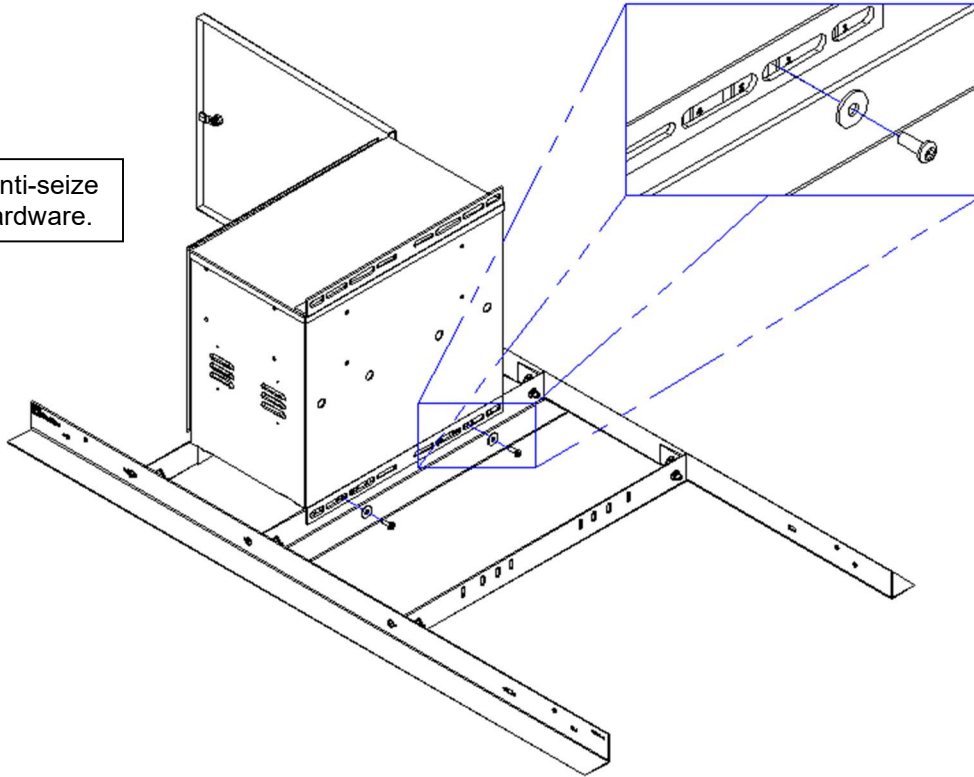

6. Tighten all hardware using 1/2" wrench to 10-12 ft-lb torque.
7. Check the enclosure is fully secured to the base and aligned correctly.

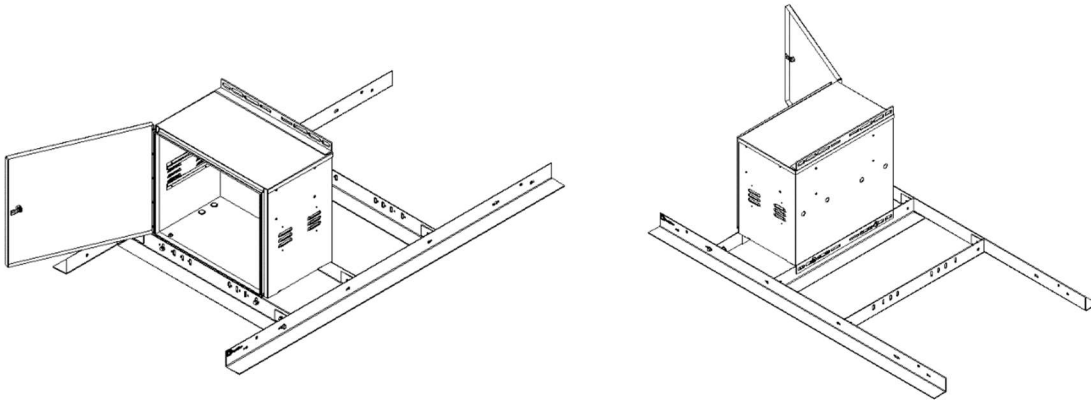

M2-31 Enclosure Mounting

1. Bolt the loose base cross rail through the slot on the side marked "C" using 3/8" hardware.

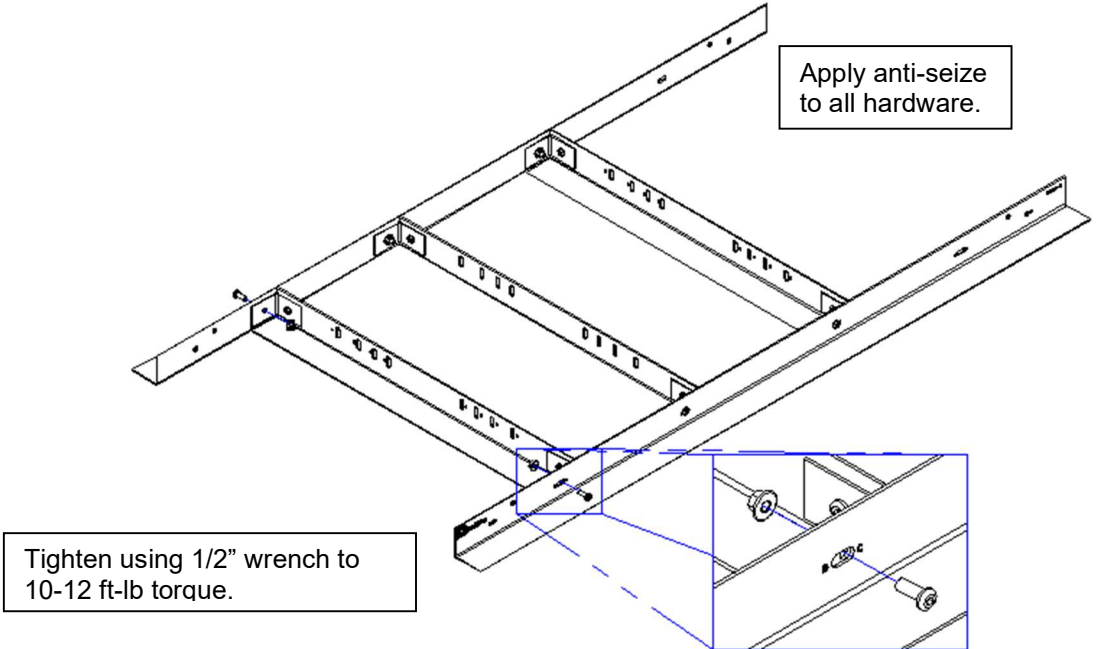

2. Install angle clips, bolting through the hole marked "3" on each side using 3/8" hardware. **Do not fully tighten.**

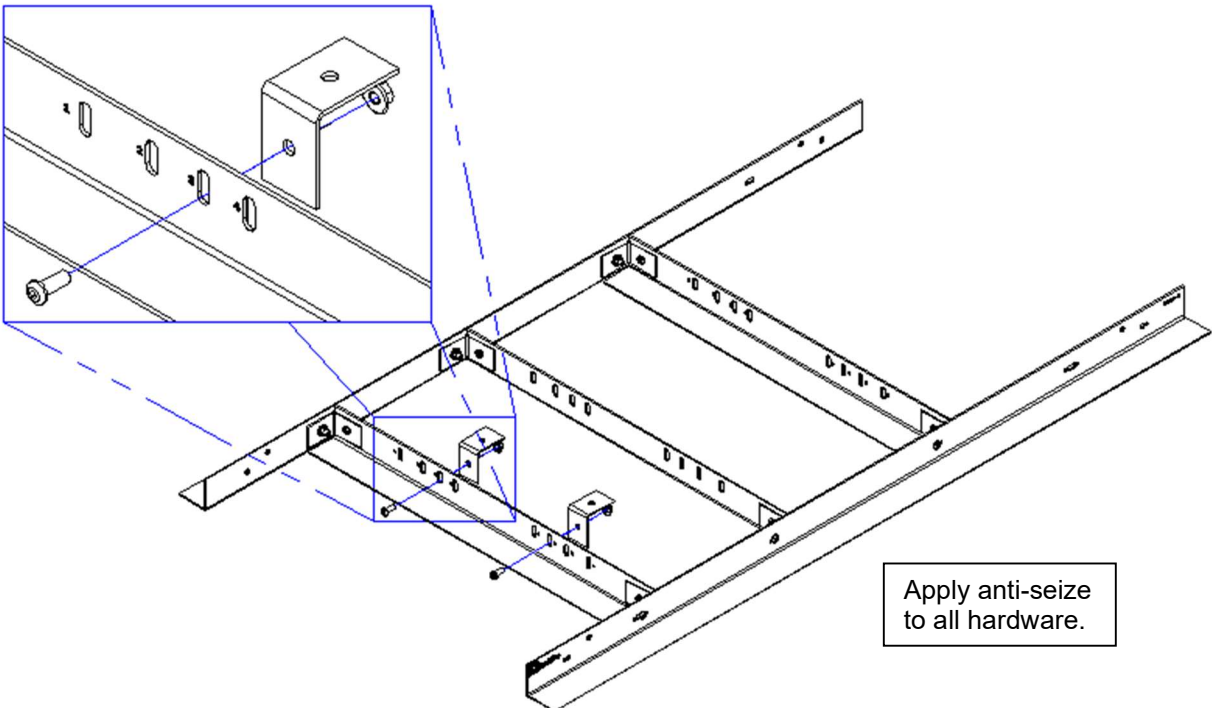

3. Turn enclosure onto its back and drill out the two existing holes in the floor of the enclosure (Shown in red) using a $\frac{1}{2}$ " drill bit.

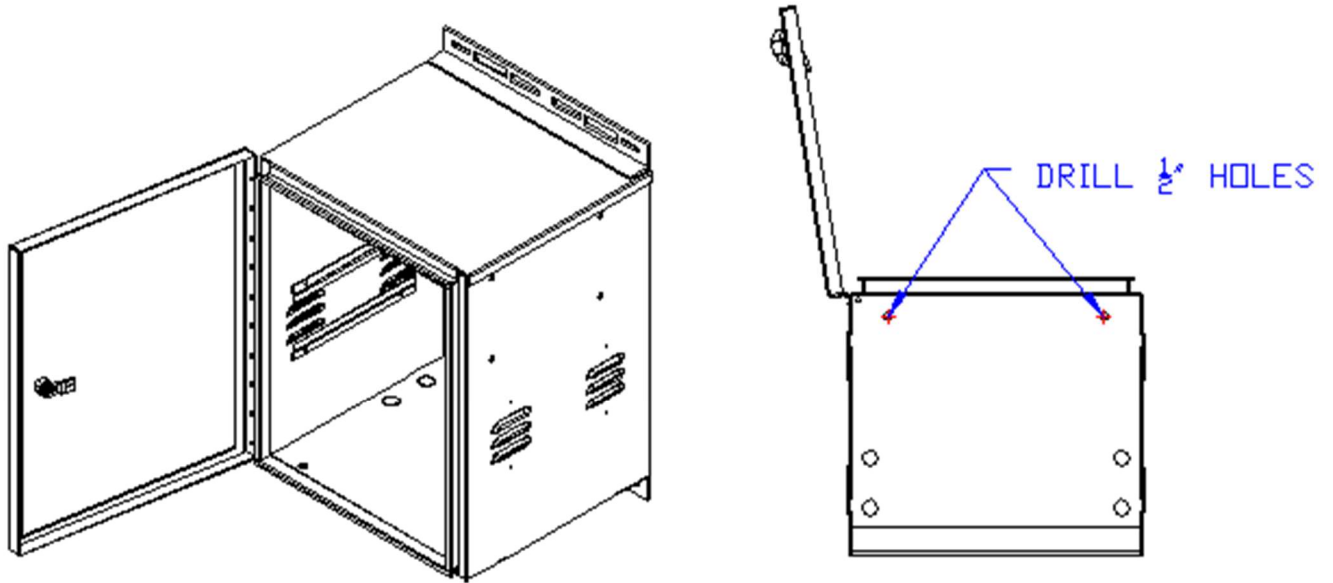

4. Lower enclosure onto angle clips and bolt through holes in the floor of the enclosure using $\frac{3}{8}$ " hardware and carriage bolts. **Do not fully tighten.**

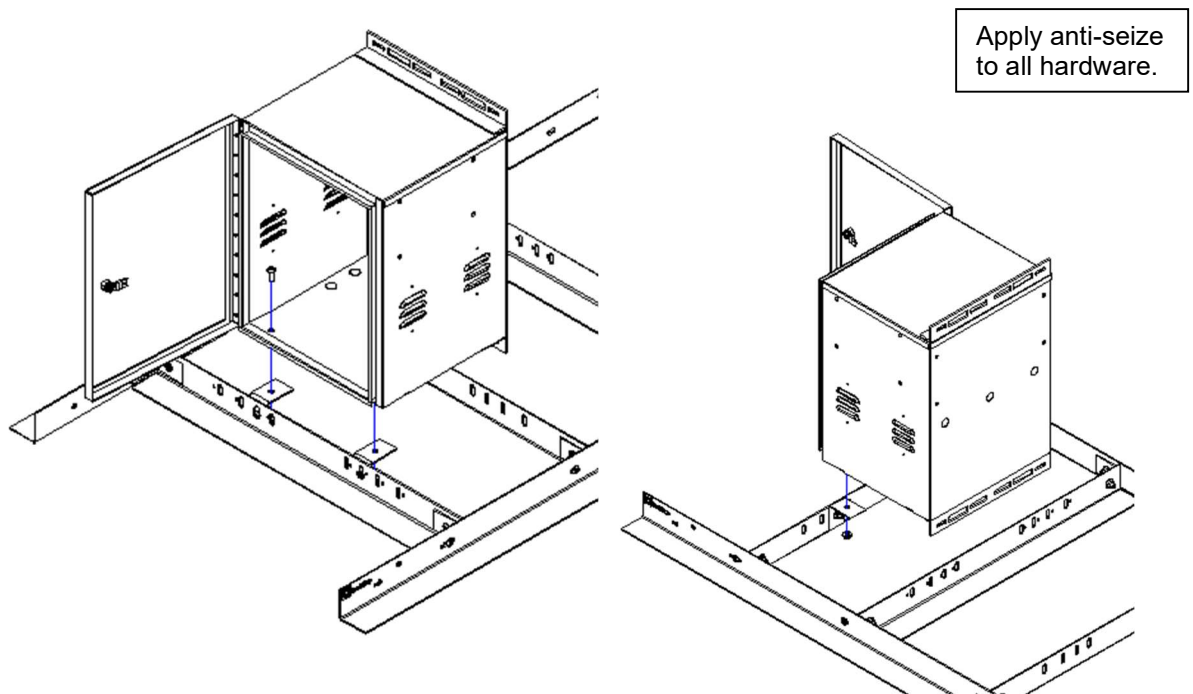

5. Bolt the rear of the enclosure to the skid through the holes marked "4" using $\frac{3}{8}$ " hardware and carriage bolts. **Do not fully tighten.**

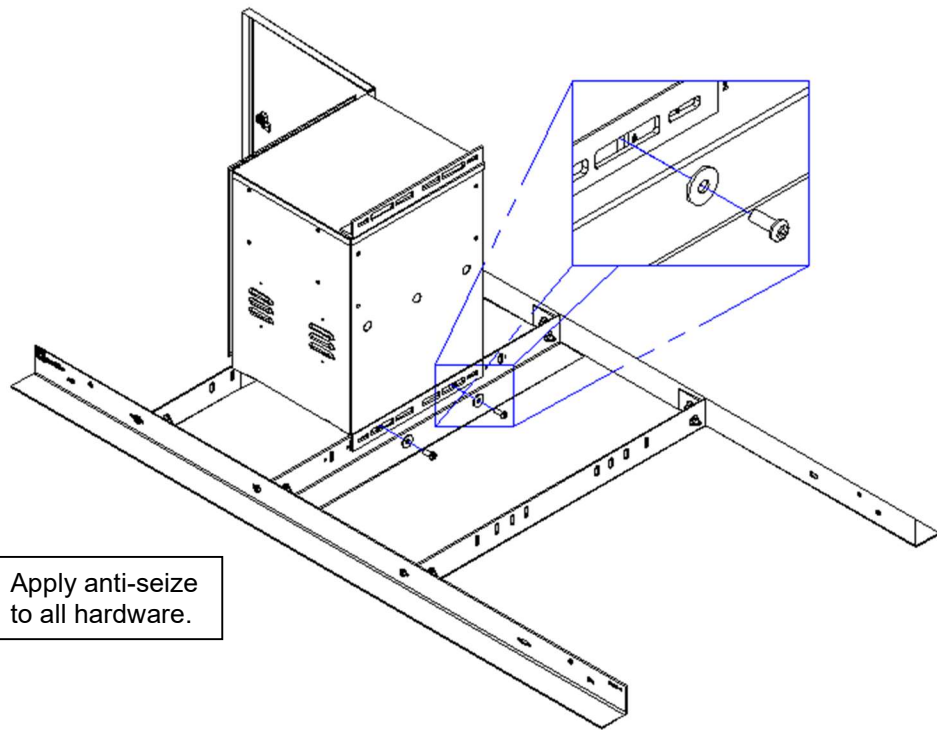

6. Tighten all hardware using 1/2" wrench to 10-12 ft-lb torque.
7. Check the enclosure is fully secured to the base and aligned correctly.

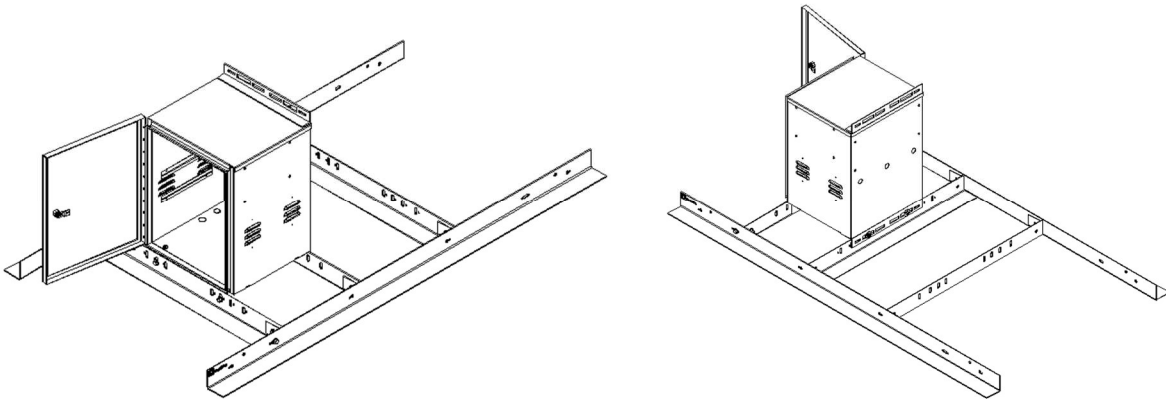

T2X8D Enclosure Mounting

1. Attach angle brackets to back of the loose base cross rail using 3/8" hardware.

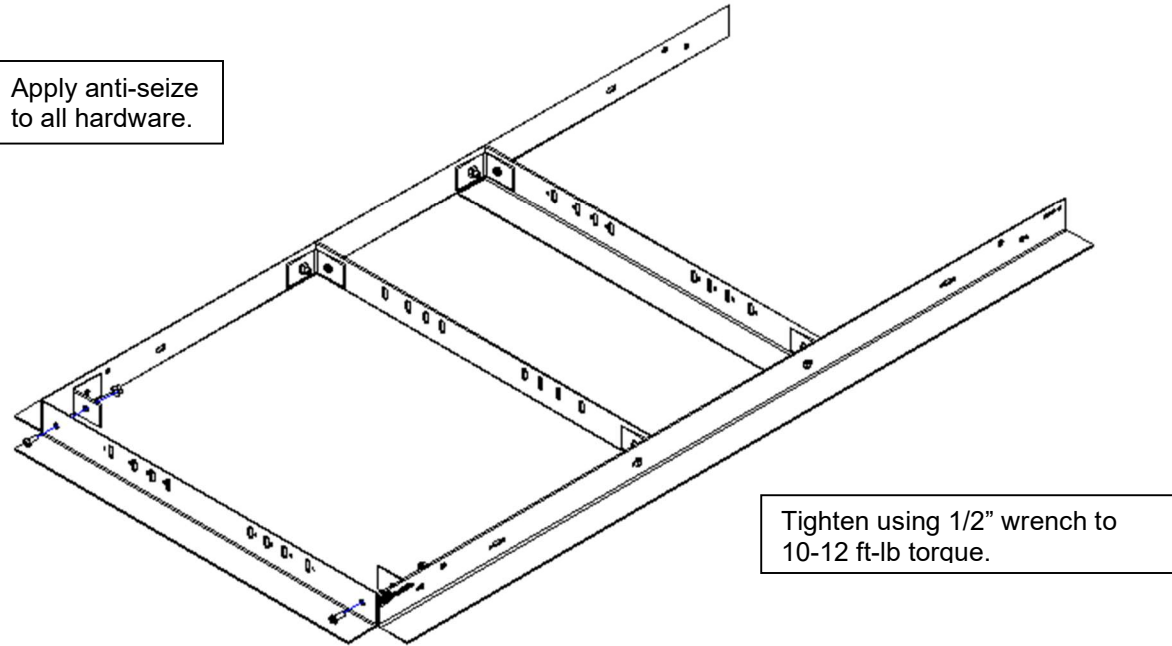

2. Bolt the loose base cross rail through the hole marked "A" using 3/8" hardware.
- 3.

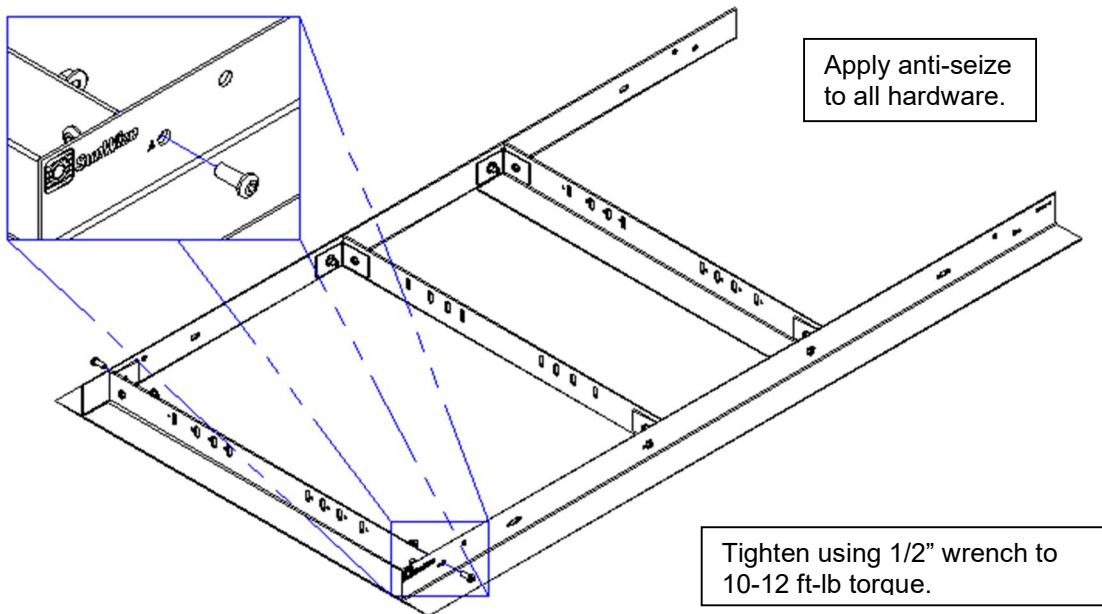

4. Install angle clips, bolting through the hole marked "2" on each side using 3/8" hardware. **Do not fully tighten.**

Apply anti-seize to all hardware.

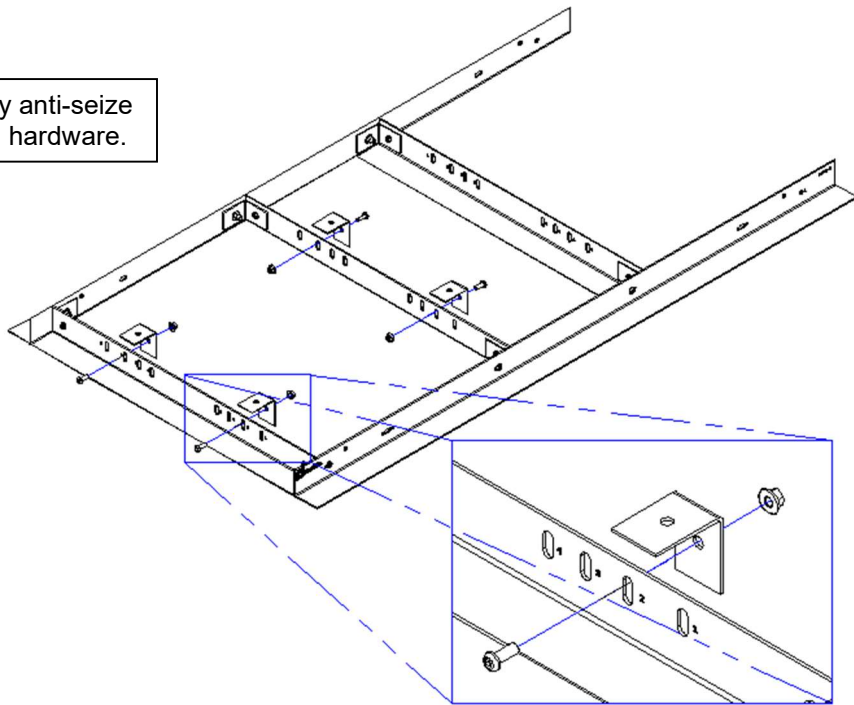

5. Lower enclosure onto angle clips and bolt through holes in the floor of the enclosure using 3/8" hardware and carriage bolts. **Do not fully tighten.**

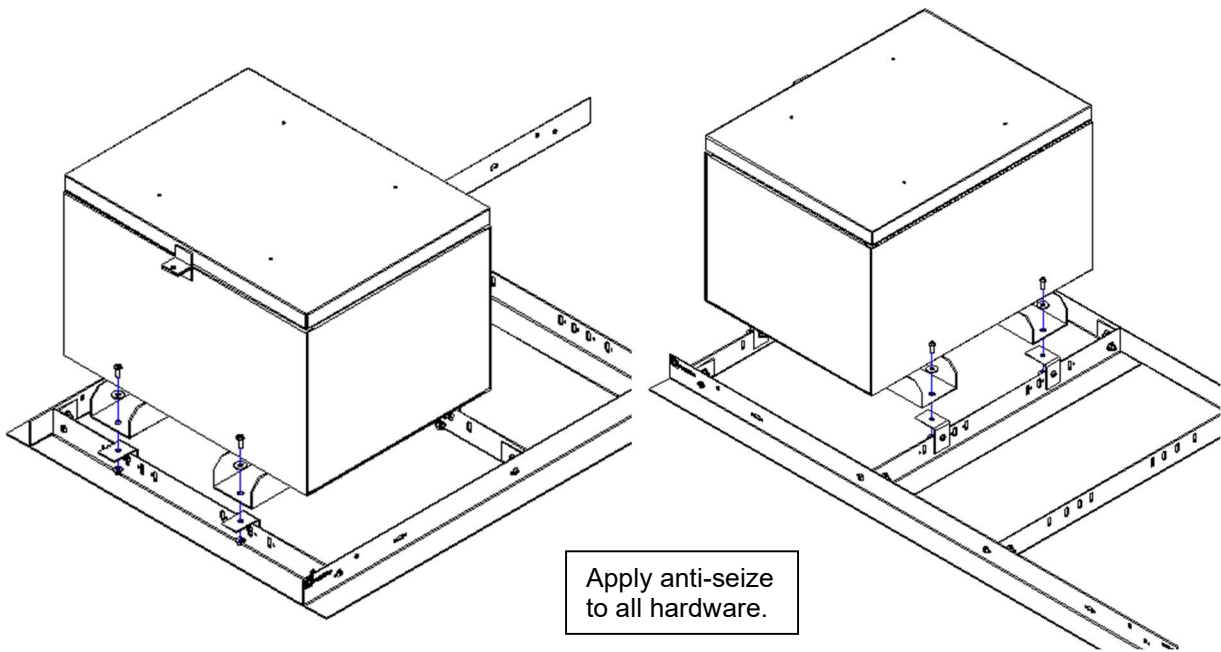

Apply anti-seize to all hardware.

6. Tighten all hardware using 1/2" wrench to 10-12 ft-lb torque.
7. Check the enclosure is fully secured to the base and aligned correctly.

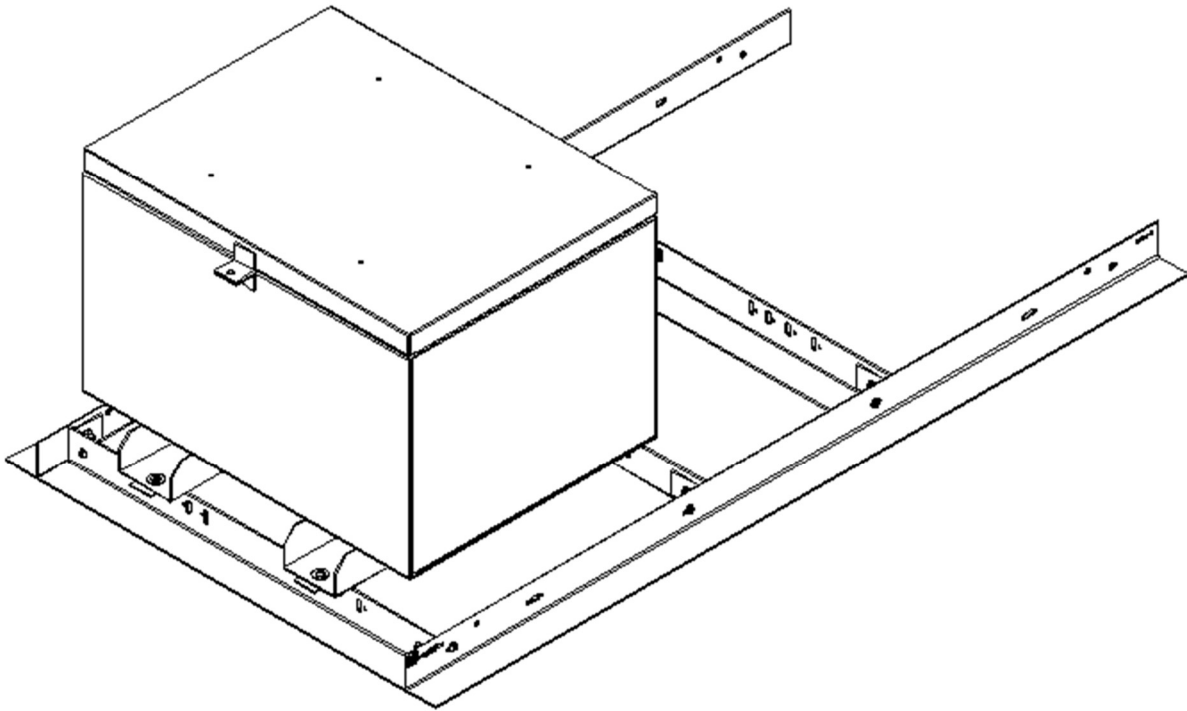

F-Series Enclosure Mounting

1. Bolt the loose base cross rail through the slot on the side marked "C" using 3/8" hardware.

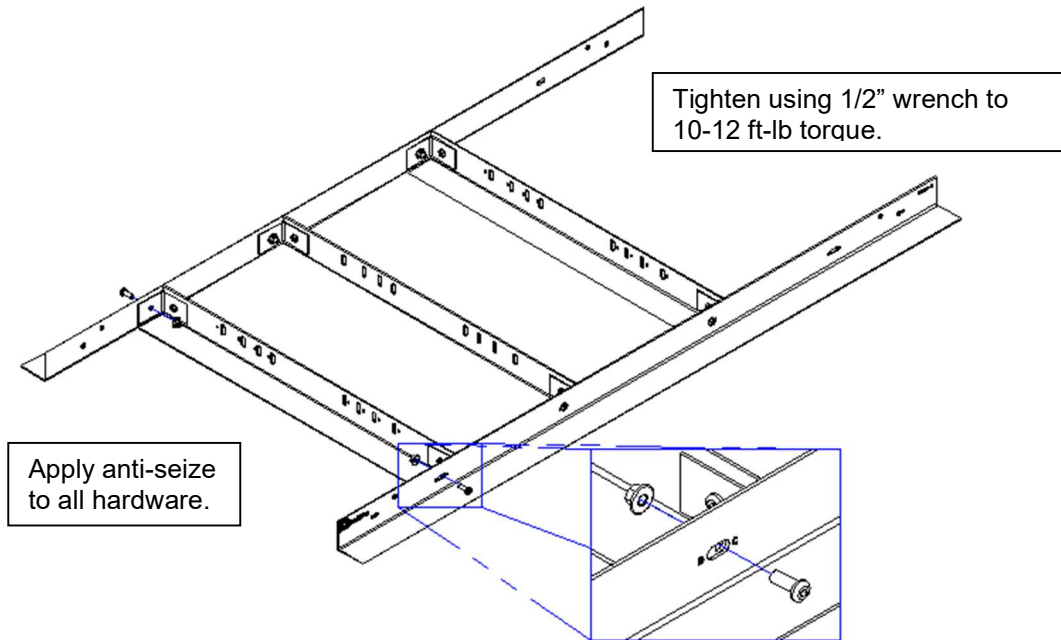

2. Install angle clips, bolting through the hole marked "3" on each side using 3/8" hardware. **Do not fully tighten.**

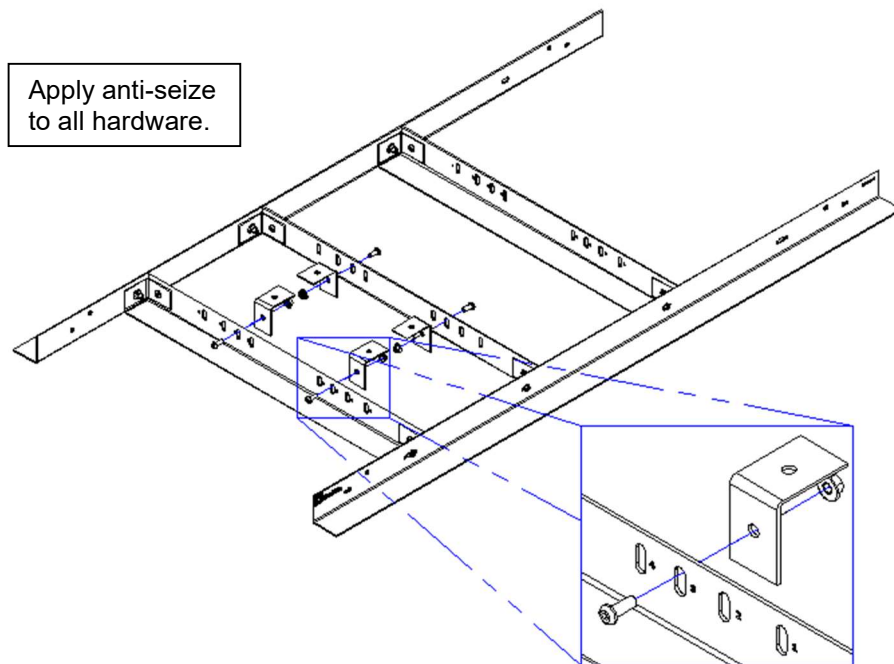

3. Turn enclosure onto its back and drill out the two existing holes in the floor of the enclosure (Shown in red) using a $\frac{1}{2}$ " drill bit. Use the hole mark page inside the enclosure to line up the holes.

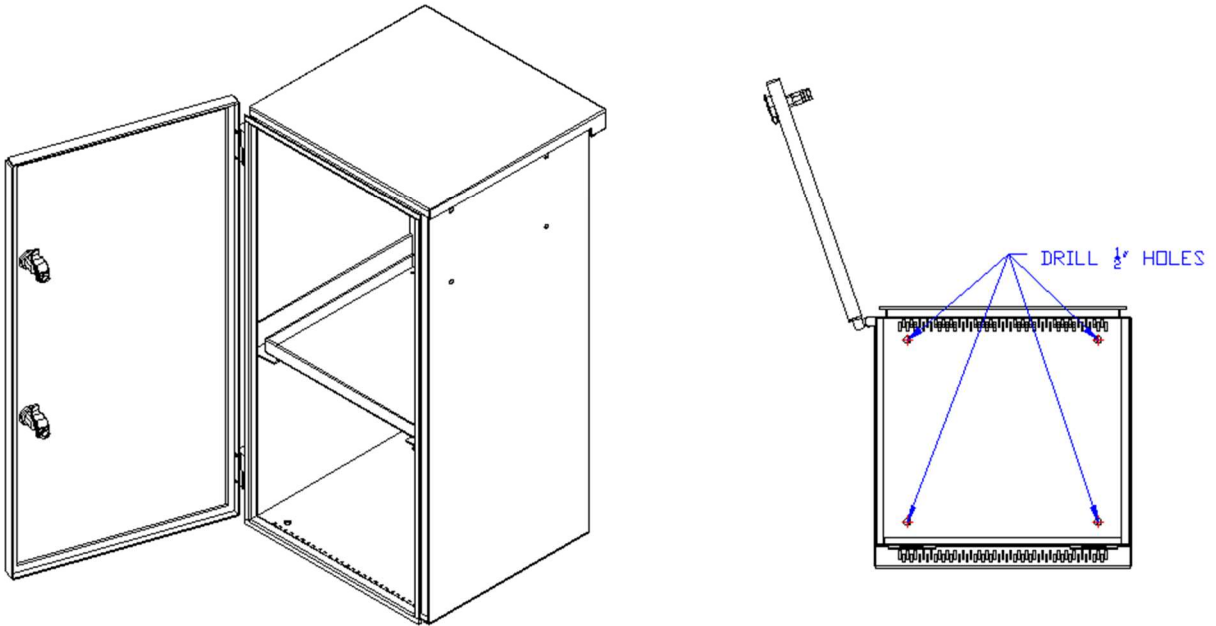

4. Lower enclosure (partially shown in blue) onto angle clips and bolt through holes in the floor of the enclosure using $\frac{3}{8}$ " hardware and carriage bolts. **Do not fully tighten.**

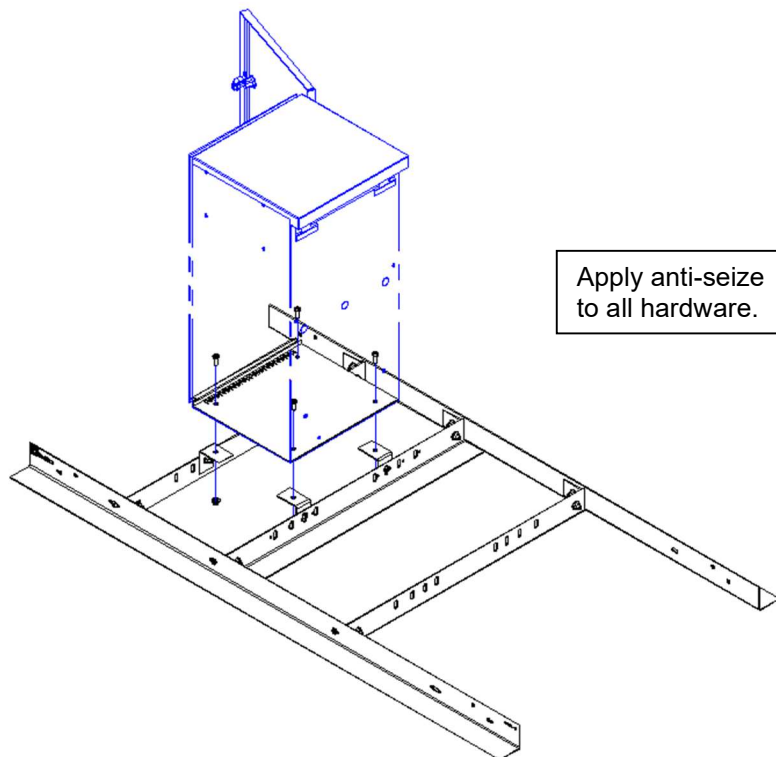

5. Tighten all hardware using 1/2" wrench to 10-12 ft-lb torque.
6. Check the enclosure is fully secured to the base and aligned correctly.

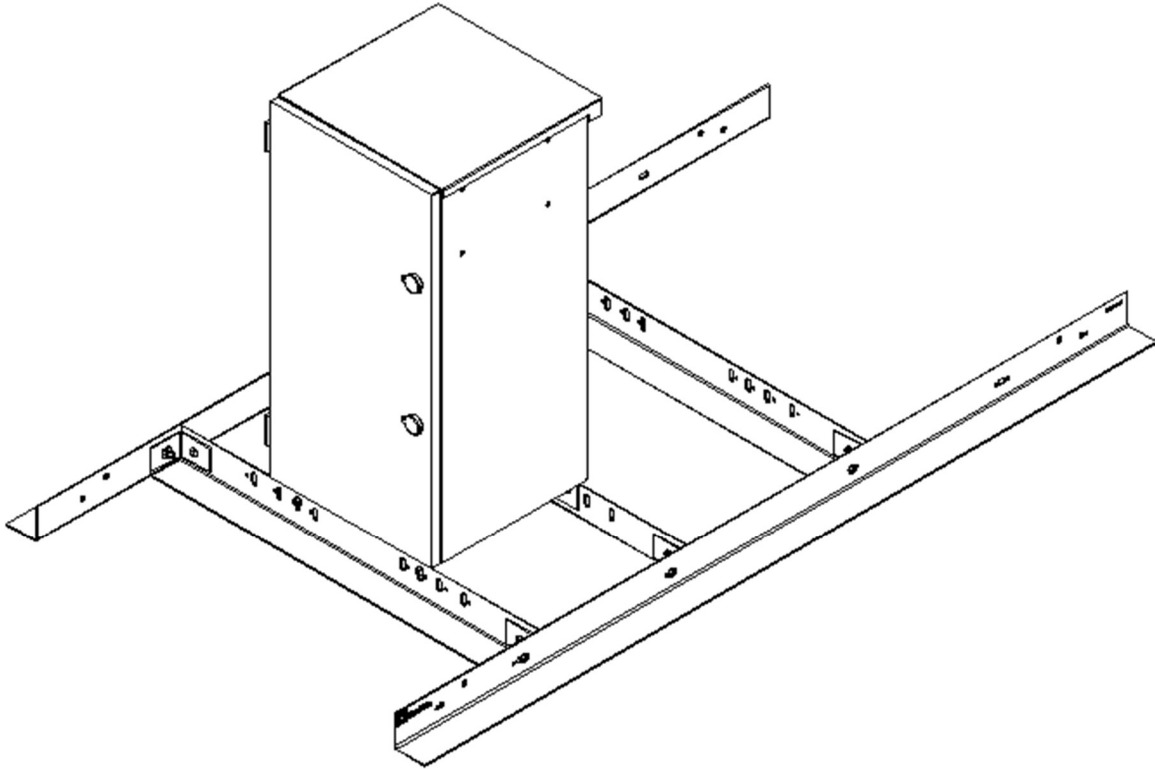

ENCLOSURE LEFT SIDE

ENCLOSURE LEFT SIDE

FOLD HERE

FOLD HERE

ENCLOSURE DOOR

ENCLOSURE BACK

ENCLOSURE DOOR

ENCLOSURE BACK

FOLD HERE

FOLD HERE

FOLD HERE

FOLD HERE

FOLD HERE

FOLD HERE

ENCLOSURE RIGHT SIDE

ENCLOSURE RIGHT SIDE

$1\frac{5}{16}$ "

$1\frac{5}{16}$ "

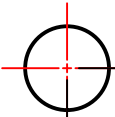

$1\frac{5}{16}$ "

$1\frac{7}{16}$ "

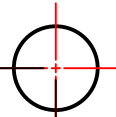

$1\frac{5}{16}$ "

$1\frac{5}{16}$ "

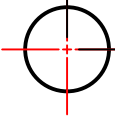

$1\frac{7}{16}$ "

